

0 611 235 803; 843

Issue } 07-01-11 **Fig./Abb. 1**

Austrastmoment 18 - 22Nm
Slipping point of clutch
Couple de glessement
Momento de desenclavamiento

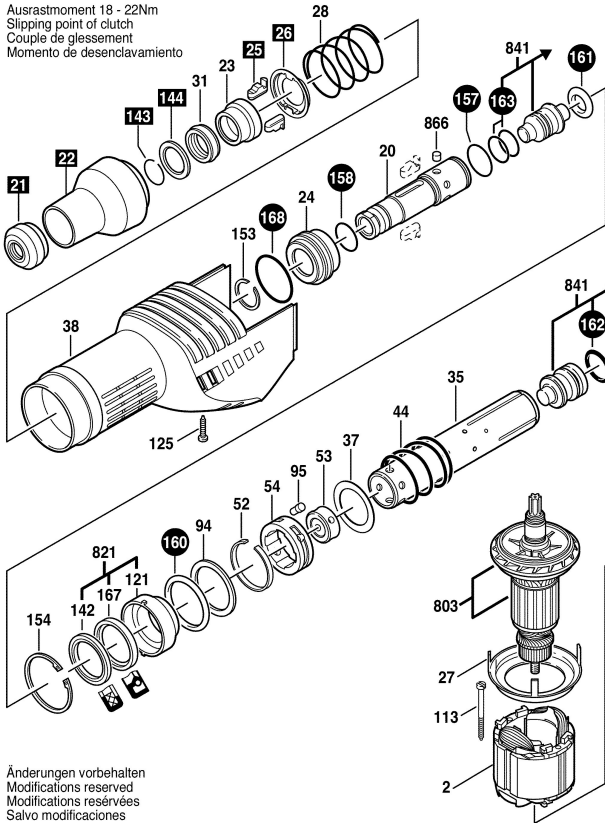

Änderungen vorbehalten
Modifications reserved
Modifications réservées
Salvo modificaciones

Zahnspeil = 0,1-0,25; Ausgleich mit Pos. 101+102
Gearplay = 0,1-0,25; adjust with pos. 101+102

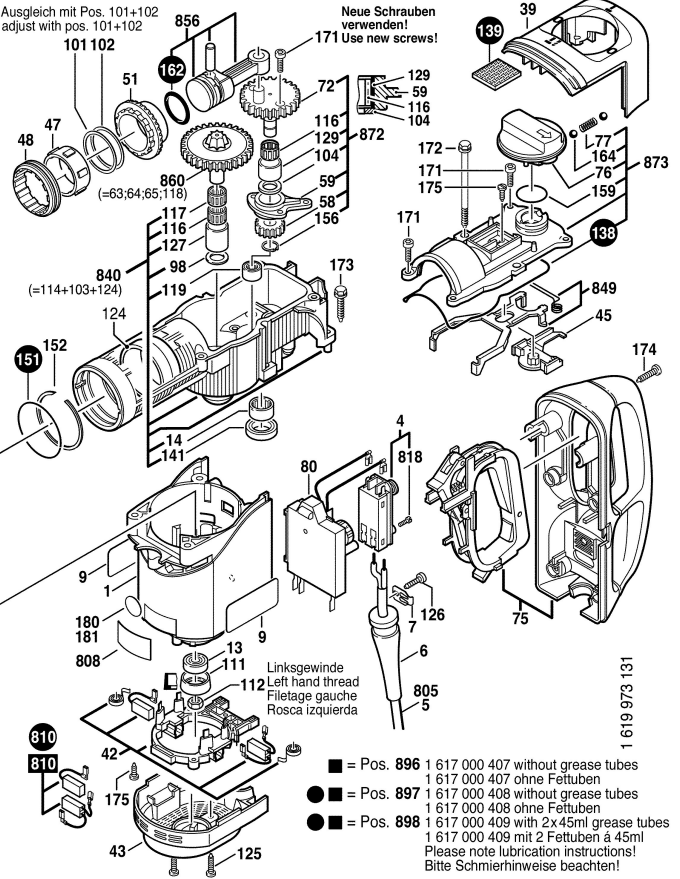

Neue Schrauben verwenden!
171 Use new screws!

Linksgewinde
Left hand thread
Filetage gauche
Rosca izquierda

- = Pos. 896 1 617 000 407 without grease tubes
1 617 000 407 ohne Fettuben
 - = Pos. 897 1 617 000 408 without grease tubes
1 617 000 408 ohne Fettuben
 - = Pos. 898 1 617 000 409 with 2x45ml grease tubes
1 617 000 409 mit 2 Fettuben à 45ml
- Please note lubrication instructions!
Bitte Schmierhinweise beachten!

1 619 973 131

0 611 235 803; 843

Issue } 07-01-11 **Fig./Abb. 2**

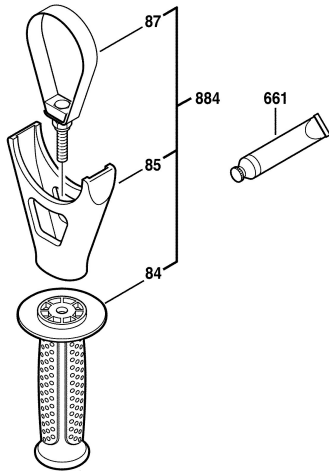

Neue Ausführung
New execution
Nouvelle exécution
Nueva ejecución

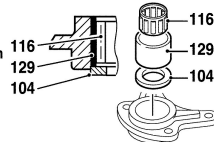

Alte Ausführung
Old execution
Ancien exécution
Vieja ejecución

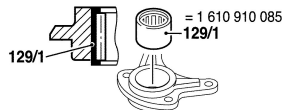

Änderungen vorbehalten
Modifications reserved
Modifications réservées
Salvo modificaciones